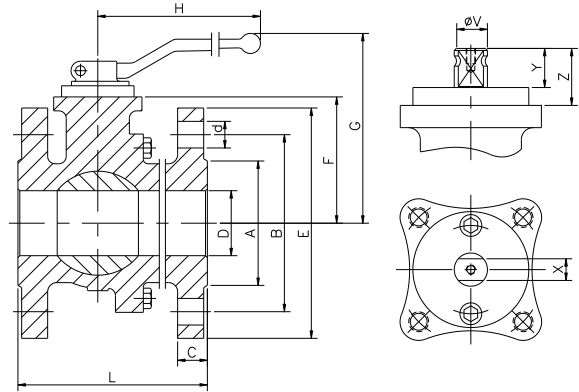
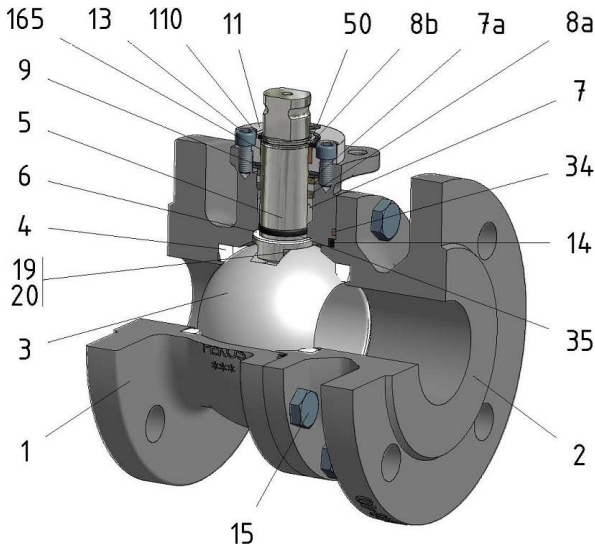

FIG.Z 04 TTTGV PN40 DN15/125 F4-F5



Position	Description	Material
01	Body 1	C.S. 1.0619
02	Body 2	C.S. 1.0619
03	Ball	S.S. 1.4408
04	Seat	PTFE (modified)
05	Stem	S.S. 1.4401
06	Stem seal	PTFE (modified)+FG
07	Stem packing	PTFE (modified)
07a	Stem packing 2	Graphite
08a	Gland packing 1	S.S. 1.4401
08b	Gland packing 2	S.S. 1.4401
09	Spring washer	S.S. 1.4310
11	Cover	S.S. 1.4408
13	Cover bolt	A4-70
14	Body seal 1	PTFE (modified)
15	Body bolt	A2-70
16	Handle	WCB
17	Handle bolt	1.045(8.8)
19	Spring washer	S.S. 1.4401
20	Antistatic ball	S.S. 1.4401
34	Body seal 2	Graphite
35	O ring stem	FKM
50	Subjection ring	S.S. 1.4301
110	Subjection ring seal	S.S. 1.4401 Nitrided
165	Stem bearing	PTFE (modified)+FG

General features

- Floating ball.
- Split body.
- Full bore.
- Soft seat.
- Bidirectional.
- Anti Blow out proof stem.
- Autoadjustable packing.
- Anti static device.
- Self-cavity pressure relief.

Standards

- Top flange ISO 5211
- Flanges EN 1092-01
- Face to face EN 558
- Testing EN-12266, ISO 5208
- Design EN-12516, ISO 17292

Official approvals

- CERTIFICATE FIRE SAFE
- TÜV.AD-MERKBLATT A4
- TA-LUFT VDI 2440
- ISO 15848-1
- ATEX 2014/34/EU
- PED 2014/68/EU
- SIL 3 CAPABLE
- EN 161/EN ISO 23553-1

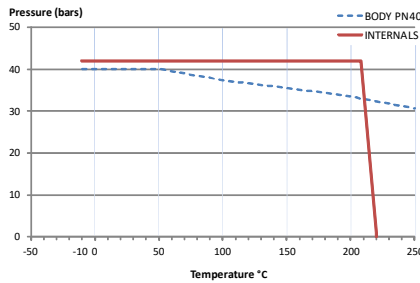

PEKOS GROUP CERTIFICATES:

ISO 9001: 2015 / 2014/68/EU / API-6D



DIMENSIONS & Technical information

DN	PN	D	L	E	A	B	C	F	H	G	V	X	Y	Z	n x d	ISO 5211	Torque	MAST	Weight
15	40	15	115	95	45	65	16	52	185	100	14	11	11	14	4 x 14	F05	12	44	3
20	40	20	120	105	58	75	18	54	185	102	14	11	11	14	4 x 14	F05	14	44	4
25	40	25	125	115	68	85	18	60	185	110	18	14	17	20	4 x 14	F05	18	95	5
32	40	32	130	140	78	100	18	65	185	115	18	14	17	20	4 x 18	F05	30	95	6
40	40	40	140	150	88	110	18	75	293	129	22	17	20	30	4 x 18	F07	40	250	8
50	40	50	150	165	102	125	20	83	293	137	22	17	20	30	4 x 18	F07	65	250	11
65	40	65	170	185	122	145	22	96	293	150	22	17	20	30	8 x 18	F07	85	250	17
80	40	80	180	200	138	160	24	114	450	187	28	22	22	40	8 x 18	F10	130	523	22
100	40	100	190	235	162	190	24	128	450	201	28	22	22	40	8 x 22	F10	190	523	30
125	40	125	325	270	188	220	26	158	740	247	36	27	35	50	8 x 26	F12	350	1073	62

** Depending on service conditions.

* Dimensions are in mm.

* Torque & MAST are in Nm.

* Weight is in Kilograms

* Torque values have been measured ΔP at maximum rating at room temperature